

Post-Hybridization Processing of Spotted Oligo Arrays

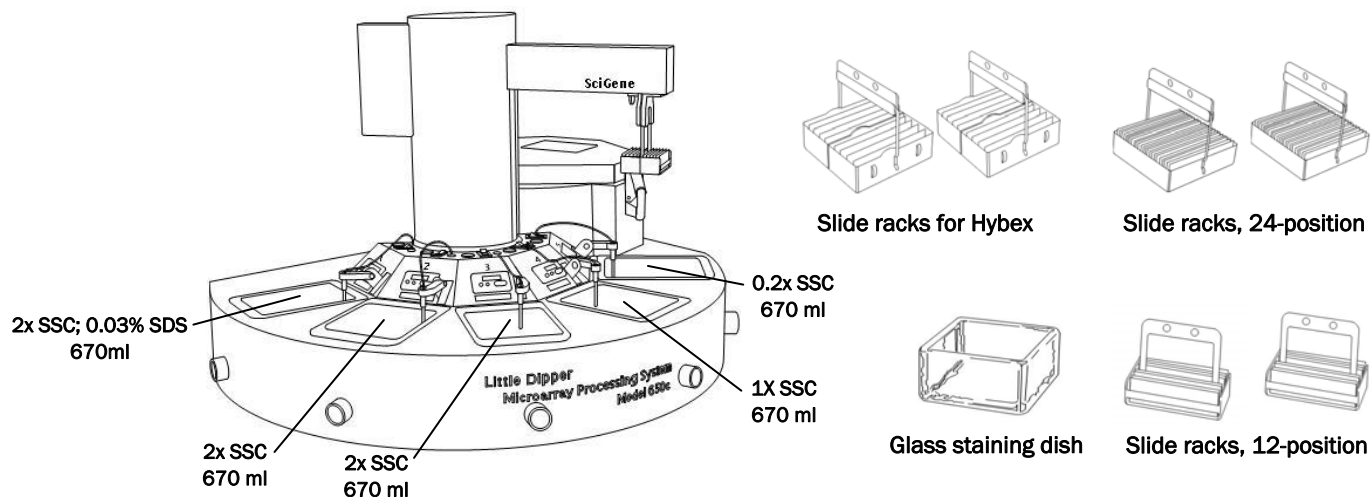

Equipment Configuration

- **Little Dipper Processor for Self-Spotted Arrays**, 115v/220v. (SciGene cat. #1080-50-1/1080-50-2)
- **4x Slide racks for Hybex**. (SciGene cat. #1057-32-3, 2/pk)
- or- **2x Slide racks, 24 position**. (SciGene cat. #1080-20-0)
- or- **2x Slide racks, 12 position for 3 inch slides**. (SciGene cat. #1080-20-1)
- **Glass staining dish**. (Fisher cat. #08-812 for 12-position racks) (Wheaton cat. #900303 for Hybex or 24-position racks)

– Optional Equipment

- **Hybex Microarray Incubation System**, 115v/220v. (SciGene cat. #1057-36-1/1057-36-2)
- **NoZone or NoZone TL Workspace**, 115v/220v. (SciGene cat. #1090-00-1/1090-00-2)

Buffer Preparation

- **2x SSC; 0.03% SDS**
1400 ml working solution – dilute 140 ml, 20x stock SSC solution with 1116ml, RNase-free water. Add 4.2 ml of 10% SDS and gently mix to avoid bubbles.
- **2x SSC**
1400 ml working solution – dilute 140 ml, 20x stock with 1120 ml, RNase-free water
- **1x SSC**
700 ml working solution – dilute 35 ml, 20x stock with 630 ml RNase-free water
- **0.2x SSC**
700 ml working solution – dilute 7 ml, 20x stock solution with 686 ml of RNase-free water

Instrument Setup

1. Wash the removable baths and the processing racks with warm water, rinse with DI water and dry with lint-free towels. Do not use detergent.
2. Place clean baths into the unit and rotate the temperature sensors to the down position.
3. Using the touch screen, create a protocol named **Oligo Arrays** or similar and enter the agitation rates and times for the baths and centrifuge time shown in Table 1. Consult the **Little Dipper User Manual** for details on creating and editing protocols.
4. Fill baths with the buffers and volumes shown in Table 1.
5. Turn on main power to the instrument and the individual power switch to Bath # 1 only and set the temperature on the controller to 55 °C. Wait approximately 10 minutes for the temperature of the buffer to stabilize.

Table 1. Little Dipper Program for Self-Spotted Oligo Arrays.

Bath Position	Buffer	Volume (ml)	Temp (°C)	Agitation (cpm)	Time (sec)
1	2x SSC; 0.03% SDS	670	55°	400	60
2	2x SSC	670	RT	400	30
3	2x SSC	670	RT	400	30
4	1X SSC	670	RT	400	90
5	0.2x SSC	670	RT	400	90
C	–	–	–	–	300

Continued on next page...

Post-Hybridization Processing of Spotted Oligo Arrays

Load Arrays / Run Protocol

1. Turn on the ozone scrubber on the NoZone Workspace (if used) at least 10 minutes prior to operating the processor.
2. Open the centrifuge, remove the black spacer frame from the green bucket, replace absorbent pad (SciGene cat. #1080-21-0) and reinstall spacer frame. Ensure spacer frame is in place in the red, balance bucket and insert a rack identical to that used for processing the arrays with the same number of slides to balance the centrifuge. Consult the **Little Dipper Operations Guide** for important details.



Load balance rack with care! Handle must be parallel to the axis of rotation, with rack seated atop black spacer.

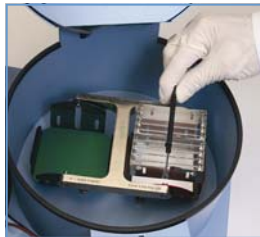

3. Remove arrays from hybridization cassettes and insert them into either the 24 position rack or 12 position rack submerged in 2x SSC; 0.03% SDS in the glass dish. Attach the Little Dipper processing handle if using the 24 position rack, following the **Operations Guide**.

— Or —

Remove Hybex racks containing 4 arrays each from the hybridization chamber. Keeping the rack oriented so the arrays remain horizontal, place them into the glass dish containing 2x SSC; 0.03% SDS and flip the racks on their sides so that the coverslips fall off. Attach the Little Dipper processing handle. Agitate the racks up and down to aid in coverslip removal. Consult the **Hybex Microarray Incubation System User Manual** for details.

4. Working inside the NoZone Workspace, quickly move the rack with arrays from the dish to Bath #1, minimizing the time that arrays are exposed to the air. Start the **Oligo Array** protocol using the touch screen and load the rack on the gripper as described in the **Operations Guide**.
5. Close the NoZone Workspace door (if used).
6. After the processor is finished, open centrifuge, remove sample rack and recover arrays. Store in a clean, ozone-safe environment until scanned.

— End Protocol —

All third party marks are the property of their respective owners.